

Phillips PAN Self Drilling Screw

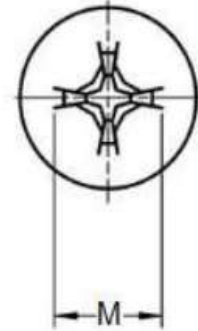
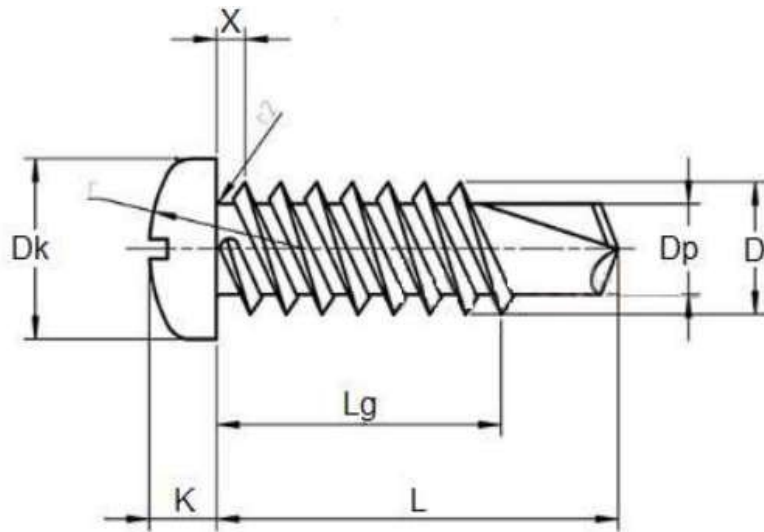

MVD PART NO DESIGNATION

MV 7504 N LX S/SS XX
 ↓ ↓ ↓ ↓ ↓
 DIN NO THREAD LENGTH MATERIAL PLATING

Screw thread D			ST2.9	ST3.5	(ST3.9)	ST4.2	ST4.8	ST5.5	ST6.3
Dk	nominal=max.		5.5	6.8	7.5	8.1	9.5	10.8	12.4
	min.		5.2	6.44	7.14	7.74	9.14	10.37	11.97
K	approx.		1.7	2.1	2.3	2.5	3	3.4	3.8
r	max.		1.1	1.4	1.5	1.6	1.9	2.1	2.4
Cross recess		No.	1	2	2	2	2	3	3
Type H	m	approx.	3	4.2	4.6	4.7	5.1	6.8	7.1
	Penetration depth	min.	1.4	1.62	2.03	2.11	2.59	2.95	3.33
		max.	1.7	2.12	2.53	2.62	3.1	3.53	3.91
Type Z	m	approx.	2.8	4	4.2	4.4	5	6.3	7
	Penetration depth	min.	1.48	1.6	1.85	2.05	2.64	2.72	3.38
		max.	1.73	2.06	2.31	2.51	3.1	3.16	3.84

SPECIFICATIONS & DETAILS

MVD PART CODE	MVN7504NXXX	MVD DESCRIPTION	SELF DRILLING PAN PHILL SS304 NOXXX
DRAWN BY	ABHISHEK	APPROVED BY	MAGESH
DRAWING REV. NO	00	MATERIAL	STAINLESS STEEL
DATE		FINISH	SELF FINISH

ALL DIMENSIONS ARE IN MM, UNLESS SPECIFIED

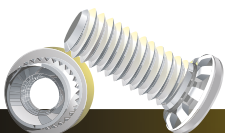

#308, Jigani-Bommasandra Link Road, Jigani, Anekal Taluk, Bengaluru - 560 105, INDIA.